

## °M Warmer System with °M Station

---

Blood and IV-fluid warming system





	Page
1. INTRODUCTION .....	4
2. INDICATION FOR USE .....	4
3. CLINICAL AND EDUCATIONAL INFORMATION .....	5
4. GENERAL INFORMATION ABOUT THE °M WARMER SYSTEM WITH °M STATION .....	5
5. OVERVIEW OF °M WARMER SYSTEM WITH °M STATION.....	5-7
6. UNPACKING OF THE °M WARMER SYSTEM WITH °M STATION.....	7
7. SETTING UP THE °M STATION.....	8-9
8. USE OF THE °M WARMER SYSTEM WITH °M STATION .....	10-17
9. END THE USE OF THE °M WARMER SYSTEM WITH °M STATION .....	18
10. USER INTERFACE AND ALARMS ON THE °M WARMER SYSTEM WITH °M STATION.....	18-20
11. MAINTENANCE AND CLEANING .....	20-21
12. DISPOSAL .....	21
13. OPERATING TEMPERATURE RANGE .....	22
14. SAFETY INFORMATION.....	22-24
15. SYSTEM ERROR AND SERVICE.....	25
16. SYMBOLS.....	26-27
17. TECHNICAL SPECIFICATIONS.....	28-30
18. ELECTROMAGNETIC COMPATIBILITY .....	30-36
19. ORDERING INFORMATION.....	37

## 1 INTRODUCTION

This manual provides the user the information needed to successfully implement and operate the °M Warmer System with °M Station. This guide neither replaces a formal education nor training in the use of intravenous infusion systems, as may be required by local regulations.

 Before the °M Warmer System with °M Station is used, the user manual for the °M Warmer System with °M Station should be thoroughly read.

 Follow AABB's 'Guidelines for the Use of Blood Warming Devices', which warns against heating when administering platelets, cryoprecipitate, or granulocyte suspensions.

 Some medicaments or compositions may be sensitive to heating. As is the case with all systems for heating liquids and blood, the manufacturer's instructions regarding heat sensitivity should be carefully read before use.

 The use of inline air and particulate filters is not contraindicated for the °M Warmer, when deemed appropriate by the treating clinician's judgement and in accordance with local clinical guidelines and practices, and with filter manufacturer's instructions for use.

 Do not pass medications through the °M Warmer. If needed, infuse the medications after the °M Warmer.

 Do not use °M Warmer with infusions fluids with a pH lower than 3 or higher than 8.

## 2 INDICATION FOR USE

The °M Warmer System with °M Station is intended to warm blood, blood products and intravenous fluids prior to administration. It is designed to be used by healthcare professionals in hospital, clinical settings and in ground based medical vehicles to reduce the risk of hypothermia in the patient.

### 3 CLINICAL EDUCATIONAL INFORMATION

It is assumed that before the °M Warmer System with °M Station is used, the users are trained to set up and use blood/IV fluids in a medically approved manner that includes aseptic techniques and standard hospital procedures.

The °M Warmer System with °M Station can, when administered properly, help prevent hypothermia and the complications from hypothermia. The device will also make the patient feel more comfortable during IV infusions.

### 4 GENERAL INFORMATION ABOUT THE °M WARMER SYSTEM WITH °M STATION

The °M Warmer System with °M Station is a heating system for intravenous infusion. The °M Warmer System with °M Station can heat the fluid/blood from 5°C up to 37°C at flow rates up to 150 ml/minute.

At low flow rates, the output temperature will be up to 42°C, and at flow rates higher than 150ml/min, the output temperature will be lower than 37°C.

### 5 OVERVIEW OF °M WARMER SYSTEM WITH °M STATION

Information regarding the °M Warmer System with °M Station can be found in:

- The user manual for the °M Warmer System with °M Station (this manual – included with each system)

You can order the latest edition of the manual by sending an e-mail to [support@mequ.dk](mailto:support@mequ.dk) and write User Manual in the subject line. Also, please specify which language you want the instructions in. You will then receive operating and maintenance instructions in a PDF version. All specifications are subject to change without notice.

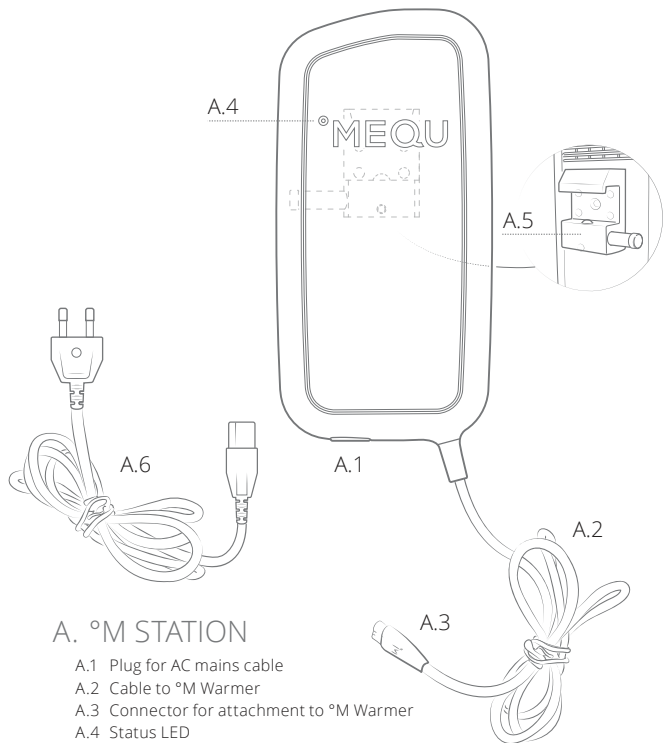

### A. °M STATION

- A.1 Plug for AC mains cable
- A.2 Cable to °M Warmer
- A.3 Connector for attachment to °M Warmer
- A.4 Status LED
- A.5 Clamp for rail attachment
- A.6 AC mains cable

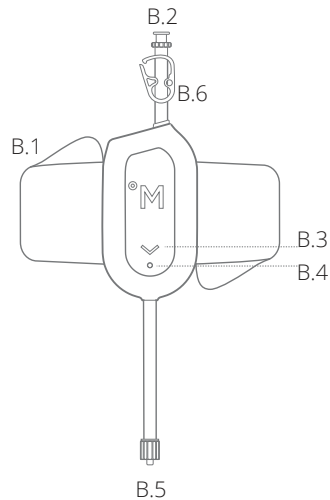

### B. °M WARMER

- B.1 Adhesive for fixation
- B.2 Luer to IV-fluid
- B.3 Function indicator arrow
- B.4 Alarm indicator
- B.5 Luer to IV-catheter
- B.6 Pinch Clamp  
(not mounted on tubing)

**THE SYSTEM CONSISTS OF 2 UNITS:**

- The °M Warmer: A disposable device with sterile fluid path that heats fluid/blood
- The °M Station: An AC power supply that supplies energy to the °M Warmer

The °M Station must only be used with the °M Warmer and not for any other use

The system comes in two boxes:

**A BOX WITH 1 °M STATION**

- 1 °M Station with cable connector to the °M Warmer device
- 1 AC cable
- 1 user manual for the °M Warmer System with °M Station

**A BOX WITH 5 °M WARMER DEVICES**

- 5 °M Warmer single use devices with sterile fluid path packed in sealed packages

Both items (°M Station and a box with 5 °M Warmers) are purchased separately  
– see ‘Ordering Information’

If all of the ordered items are not present, please contact your dealer immediately.

## 6 UNPACKING OF THE °M WARMER SYSTEM WITH °M STATION

After receiving the °M Warmer System with °M Station you must inspect the shipping boxes and their contents for damage that may have occurred during shipment. If any of the contents are visibly or mechanically damaged, or if the order is not complete, please contact your local supplier immediately.

## 7 SETTING UP THE °M STATION

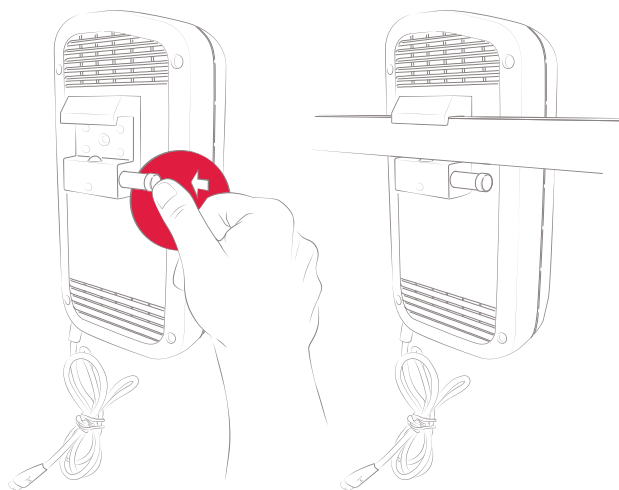

### THE °M STATION IS SET UP AS FOLLOWS:

- Attach the °M Station to the rail system\*

Keep the °M Station free of lint, dust and dirt as it may affect performance. Ensure that the vents on the back of the °M Station are unblocked. If the vents are blocked, the °M Station may overheat and shut down. If this happens, unblock the vents and let the °M Station cool down.

\* If the °M Station is to be attached to a pole, a separate adaptor is needed. Please see 'Ordering Information' for order number. The adaptor can accommodate poles with sizes from 12mm to 30mm. Make sure the pole is able to support the weight of the °M Station

- Attach the AC mains cable to the °M Station
- ⚠ The °M Station is supplied with a AC mains cable. Other AC mains cables can be used if they are approved for use with medical equipment
- Attach the AC mains cable to the AC outlet.

The green LED on the front of the °M Station lights up indicating that the °M Station is working and ready for use



Please note, that the °M Station does not have an on/off button. Shutting down the °M Station is done by turning mains power off at the AC outlet or by removing the mains cable from the °M Station

Please make sure, that the °M Station is not positioned in a way, that makes shutting down the °M Station difficult. Make sure the °M Station is dry before use

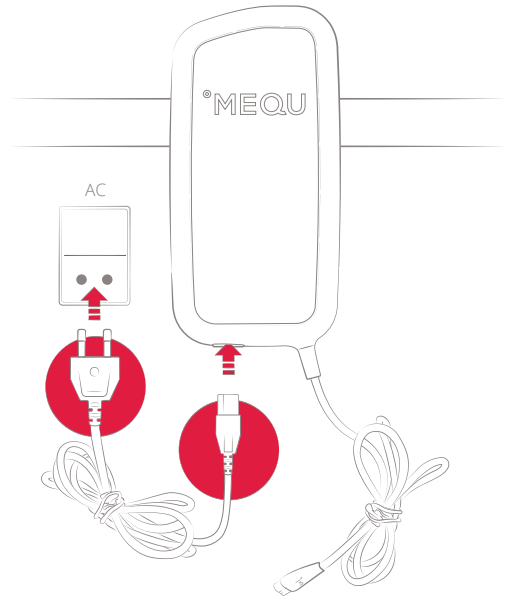
- ⚠ No modification of this equipment is allowed



## 8 USE OF THE °M WARMER SYSTEM WITH °M STATION

-  Do not use near flammable anesthetics.
-  Do not use in oxygen rich environments.

**A.**

Check that the °M Station is plugged in and that the green LED on the front is lit

**B.**

Connect an IV-giving set to an IV-fluid bag. Insert an IV/IO needle where the IV access is desired

**C.**

Take one °M Warmer and open the packaging. Remove the °M Warmer from the packaging, and remove the tamper proof seal around the Luer locks. Disconnect the Luer locks.

**NOTE:**

If you need to close the flow through the °M Warmer, you can use the supplied Pinch Clamp. Please mount the Pinch Clamp on the proximal tubing in order not to risk pulling on the venous catheter / IO needle when closing and opening the Pinch Clamp. If you do not mount the Pinch Clamp immediately, please save the Pinch Clamp for later use if needed.

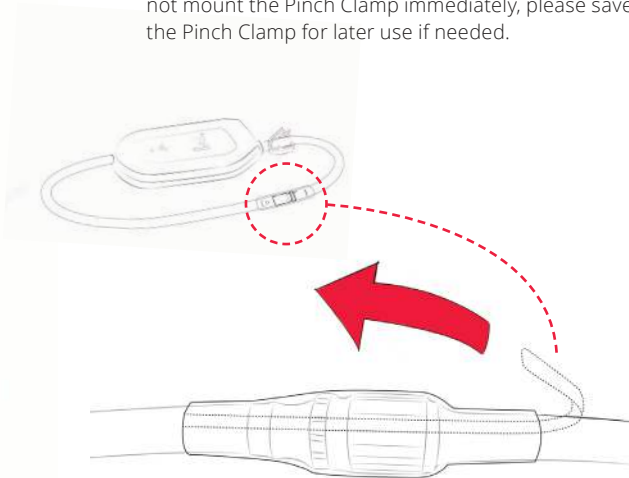

Remove tamper proof seal

- ⚠ Do not use the °M Warmer if not in original packaging.
- ⚠ Do not use the °M Warmer if the tamper proof seal around the Luer locks has been opened before time of use. Only the fluid path is sterile, the outside surface of the °M Warmer is not sterile.
- ⚠ Before use, check the expiration date of the °M Warmer device.
- ⚠ Do not use the °M Warmer System with °M Station outside the stated operating temperature range.
- ⚠ The °M Warmer is single use. Do not reuse due to risk of cross contamination.

## D.

Connect input end of °M Warmer – short tube with blue female Luer lock – to the IV- fluid administration set.

- ⚠ All IV fluid bags must be vented according to the instructions from the manufacturers of IV fluids before they are connected to the °M Warmer device.

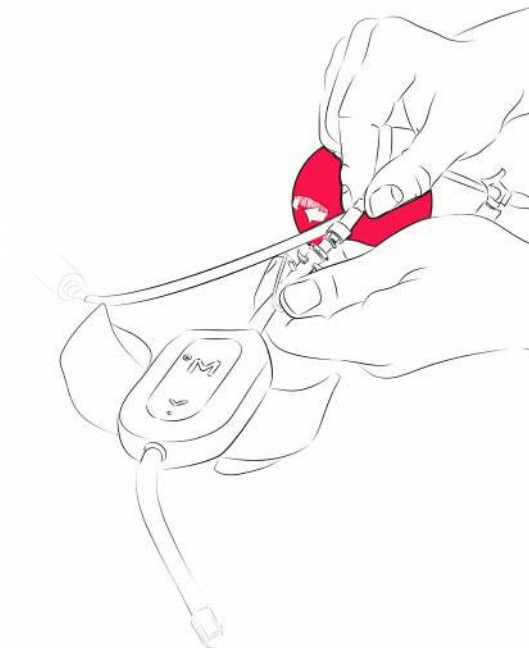

## E.

Prime the °M Warmer to remove air bubbles from the tubes and the °M Warmer by letting fluid run through the °M Warmer.

- ⚠ The standard protocols for IV tubes for purging of the infusion set and the °M Warmer must be followed before connecting to a patient.
- ⚠ Care must be taken to ensure that the fluid bag and tubing do not contain air.

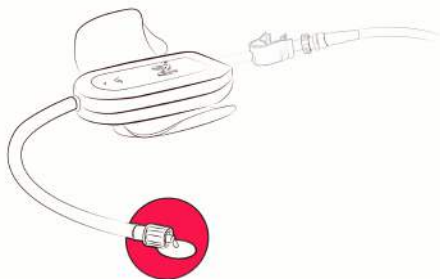

## F.

Connect output end of °M Warmer – long tube with red male Luer lock – to the IV/IO access.

- ⚠ Where clinically indicated, implement inline filtration between the °M Warmer and the access site, ensuring that the filter is compatible with the intended infusion (i.e. fluid type and flow rate).

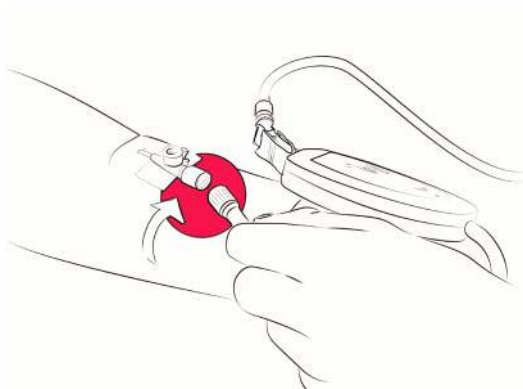

## G.

Remove the protective film from the adhesive tape on the back of the °M Warmer device and attach the warmer to the patient. Please note, that in some circumstances (e.g. wet skin) the adhesive may not stick properly. In these cases ensure fixation of the °M Warmer using other means of fixation.

**⚠** Either attach the °M Warmer to the skin of the patient or in some other way to secure that it does not fall off and pull on the infusion line. The adhesive attached to the °M Warmer may be used, but it may not be sufficient.



## H.

Connect the °M Station to °M Warmer and initiate fluid flow.

- ⚠ Do not use if °M Station shows sign of damage.
- ⚠ Do not connect/disconnect the °M Station and the warmer close to flammable agents.
- ⚠ Keep the °M Station away from the patient, as the °M Station may get hot during use.

As soon as the °M Station is connected to the °M Warmer, the red LED will blink as part of the °M Warmers self-test procedure, and then the green arrow will blink briefly indicating that the system is heating up.

When °M Warmer has reached set point temperature the arrow will be constant green.



# I.

## °M WARMER SYSTEM WITH °M STATION IS ON

The °M Warmer System with °M Station is now turned on and fluid that flows through the °M Warmer unit will be warmed to 37°C at a flow rate of up to 150 ml per minute.

- ⚠ Keep visible and regularly monitor the status indicators on the °M Warmer
- ⚠ A flashing red LED on the °M Warmer device indicates that the heating unit is too warm. Remove the connector of the °M Station. See section 10 'User Interface and alarms on the °M Warmer System with °M Station' for further information.
- ⚠ Do not use °M Warmer System with °M Station in the proximity of an MR scanner.
- ⚠ Do not place the fluid/blood bag below the IV entry point to the patient to ensure that blood/ fluid flow is not reversed.
- ⚠ The °M Warmer device should not be used for more than 72 hours.

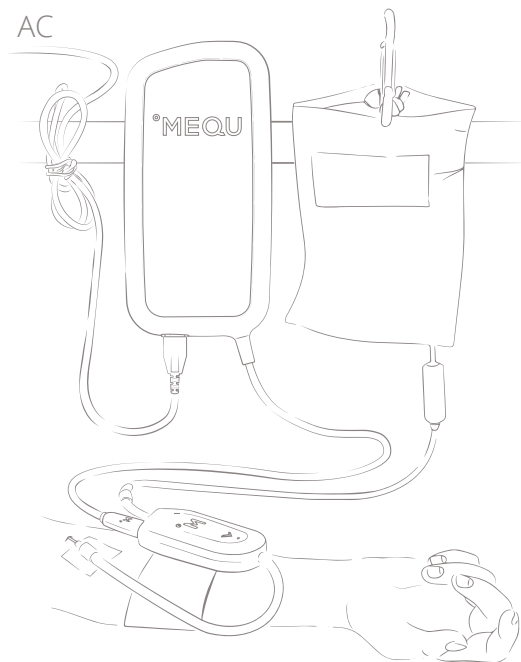

- ⚠ The °M Warmer device should only be used with °MEQU's °M Station or Power Pack and not with other power sources.
- ⚠ Do not block the vents on the back of the °M Station

## J.

### CHANGE THE FLUID BAG

If the fluid bag runs empty, there may be a need to change to a new fluid bag. To do this, follow this procedure:

- Stop the flow by closing the clamp on the tubing
- Change the fluid bag using standard procedures for changing of fluid bags during IV procedures,
- Open clamp to start the flow again

The recommended maximum static height for a bag of crystalloid solutions is 1m. At higher heights, the output temperature may be lower than  $39^{\circ}\text{C} \pm 3^{\circ}\text{C}$

## 9 END THE USE OF THE °M WARMER SYSTEM WITH °M STATION

- End the flow by closing the pinch clamp on the tube on °M Warmer.
- Disconnect the °M Station from the °M Warmer.
- Disconnect the °M Warmer from the patient and the IV-giving set. Drain any remaining liquid from the °M Warmer into a container
- Remove the °M Warmer from the patient and dispose the °M Warmer device in accordance with accepted medical practice and applicable regulations.
- Clean the °M Station. For instructions on cleaning the °M Station see section 11 'Maintenance and cleaning'.

## 10 USER INTERFACE AND ALARMS ON THE °M WARMER SYSTEM WITH °M STATION

### USER INTERFACE ON THE °M WARMER DEVICE:

- Connection for the IV-giving set: The °M Warmer device has two tubes, each with a Luer lock: The short tube with the blue female connector is connected to the infusion set, and the long tube with the red male connector is connected to IV/IO access.  
An extension tube should not be connected between the °M Warmer device and IV/IO access since at low ambient temperatures there will be a risk of temperature drop of the liquid prior to the infusion into the patient.
- Connection to the °M Station: Next to the short tube, the connector from the °M Station is plugged in.
- Fixing tape: Affixed on the back of the °M Warmer device is a piece of adhesive. This adhesive can be used for attaching the °M Warmer device to the patient. Please note, that in some circumstances (e.g. wet skin) the

adhesive may not stick properly. In these cases ensure fixation of the °M Warmer using other means of fixation.

- Green LED as indication of normal operation: The front of the °M Warmer device has a green LED shaped like an arrow. The arrow indicates the direction of the fluid. When the connector from an °M Station is inserted, the green arrow begins to flash. This means that the system is plugged in and is starting to warm up. The green arrow on the °M Warmer unit is constantly lit when temperature of 35-36°C is reached.

#### ALARM ON THE °M WARMER DEVICE:

- Red LED as a warning of too warm °M Warmer unit: A flashing red LED on the °M Warmer device indicates that the internal safety circuit has been triggered due to overtemperature. Active fluid heating has been stopped.

A flashing red LED on the °M Warmer device when fluid or blood with a temperature at the entrance of the °M Warmer unit below 37°C is infused, indicates that the °M Warmer device is defective and must be replaced.

Note! If the red LED flashes when no fluid or blood is being infused, it may be a result of the °M Warmer unit having been stored at a temperature above 37°C. This can be tested by passing fluid or blood at a temperature below 37°C through the °M Warmer – if the red LED then stops flashing, and the green LED illuminates, the system is functioning correctly and you can proceed with the infusion.

Note! The red LED flashes briefly when the °M Station is connected to the °M Warmer as part of the °M Warmer self-test procedure.

See section 15 'System Error and Service'.

## USER INTERFACE ON THE °M STATION

- Connector for AC cable: At the bottom of the °M Station, there is a connector plug for the AC cable.
- Connector for the °M Warmer: The connector at the end of the cable on the °M Station connects to the °M Warmer device.
- At the front of the °M Station there is one green LED. When lit up, the °M Station is connected to power and ready to be used
- Clamp on the back of the °M Station for mounting the °M Station to a rail system or to the pole adaptor. The clamp comes in two versions - one for DIN rails and one for DuoFlex rails

## 11 MAINTENANCE AND CLEANING

### THE °M WARMER

The °M Warmer device is a disposable device. The °M Warmer can be used on the patient for up to 72 hours. The same device must not be reused or reattached to other patients. After use, the device must be disposed - see section 'Disposal'.

### THE °M STATION

When the °M Station has been in use it must be cleaned. Cleaning should be performed immediately after the procedure to prevent soil to dry on the surface. The °M Station is resistant to the most commonly used hospital cleaners and non-caustic cleaning agents for instruments.

Approved cleaning agents for the °M Station:

- Mild cleaners (water)
- Isopropyl alcohol
- Ammonia based cleaners
- 2,4% Solution Glutaraldehyde based cleaners
- 0,3% Hydrogen Peroxide Solutions  
Chlorhexidine

## PROCEDURE

- Clean the connector, cable and °M Station on all surfaces by wiping it with a damp cloth using one of the approved cleaning agents
- Dry off the °M Station thoroughly after cleaning before using it again
- Inspect for any traces of remaining soil – repeat cleaning if any visible remaining soil on the °M Station, connector or cable.
- Do not submerge, sterilize or autoclave the °M Station

disposable products may pose a potential biological risk during or after use. Handle and dispose it in accordance with accepted medical practice and applicable regulations.

## THE °M STATION

- The °M Station is electrical and electronic equipment (as per EU directive 2012/19/EU on Waste Electrical and Electronic Equipment) and should therefore not be disposed with regular household waste. Take the product to the nearest recycling collection facility.

## 12 DISPOSAL

### THE °M WARMER

 The °M Warmer device may cause a potential biological risk during or after use. Handle and dispose in accordance with accepted medical practice and applicable regulations. The °M Warmer unit is electrical and electronic equipment (as per EU directive 2012/19/EU on Waste Electrical and Electronic Equipment) and should therefore not be disposed with regular household waste. Take the product to the nearest recycling collection facility. Also,

## 13 OPERATING TEMPERATURE RANGE

- ⚠ Operating temperature range: 0°C - 40°C
- ⚠ If °M Warmer has been stored at less than -5°C connect the °M Station before connecting °M Warmer to the IV-giving set. When arrow is green IV-fluid may be added.
- ⚠ If stored at temperatures above 43°C, the first safety circuit will be activated, meaning red LED will blink when connected to °M Station. If temperature is over 43,7°C the second safety circuit will be activated and shut down for all power. Cool down the system to below 43°C before use.

## 14 SAFETY INFORMATION

- The °M Warmer System with °M Station must only be used for its original purpose, i.e. to warm blood, blood products, colloids and crystalloid solutions prior to parenteral administration to help prevent hypothermia.
- The device must not be dismantled or tentatively repaired by any other person than the manufacturer.
- ⚠ Before the °M Warmer System with °M Station is used, the user manual for the °M Warmer System with °M Station should be thoroughly read.
- ⚠ Do not use the °M Warmer System with °M Station outside the stated operating temperature range.
- ⚠ Do not use the °M Warmer if not in original packaging.
- ⚠ Do not use the °M Warmer if the tamper proof seal around the Luer locks has been opened before time of use.

- ⚠ Do not use if °M Station shows sign of damage.
- ⚠ Do not use °M Warmer System with °M Station in proximity of an MR scanner.
- ⚠ Properly attach the °M Warmer to the skin of the patient or in some other way secure that it does not fall down and pull on the infusion-line. The adhesive attached to the °M Warmer may be used, but it may not be sufficient.
- ⚠ All IV fluid bags must be vented according to the instructions from the manufacturers of IV fluids before they are connected to the °M Warmer device.
- ⚠ The standard protocols for IV tubes for purging of the infusion set and the °M Warmer must be followed before connecting to a patient.
- ⚠ Care must be taken to ensure that the fluid bag and tubing do not contain air and therefore emerge air embolism.
- ⚠ Do not place the fluid/blood bag below the IV/IO access point to the patient to ensure that blood/fluid flow is not reversed.
- ⚠ Keep visible and regularly monitor the status indicators on the °M Warmer and the °M Station.
- ⚠ A flashing RED LED on the °M Warmer device indicates that the heating unit is too warm. Remove the connector of the °M Station. See 'User Interface and alarms on the °M Warmer System with °M Station' for further information.
- ⚠ The °M Warmer device may cause a potential biological risk during or after use. Handle and dispose in accordance with accepted medical practice and applicable regulations
- ⚠ Do not use near flammable anesthetics.
- ⚠ Do not use in oxygen enriched environments.
- ⚠ Do not connect/disconnect the °M Station and the °M warmer close to flammable agents.
- ⚠ The °M Warmer device should not be used for more than 72 hours.
- ⚠ Before use, check the expiration date of the °M Warmer device.
- ⚠ The °M Warmer device should only be used with °MEQU's °M Station or Power Pack and not with other power sources.
- ⚠ Do not block the vents on the back of the °M Station.

- ⚠ Follow AABB's 'Guidelines for the Use of Blood Warming Devices', which warns against heating when administering platelets, cryoprecipitate, or granulocytic suspensions.
- ⚠ Some medicaments or compositions may be sensitive to heating. As is the case with all systems for heating liquids and blood, the manufacturer's instructions regarding the medications' heat sensitivity should be carefully read before use.
- ⚠ Do not pass medications through the °M Warmer. If needed, infuse the medications after the °M Warmer.
- ⚠ Do not use °M Warmer with infusions fluids with a pH lower than 3 or higher than 8.
- ⚠ The °M Warmer is single use. Do not reuse due to risk of cross contamination.
- ⚠ No modification of this equipment is allowed.

Any serious incident that has occurred in relation to the device should be reported to the manufacturer and the competent authority of the Member State in which the user and/or patient is established.

## 15 SYSTEM ERROR AND SERVICE

### FAULTY °M STATION:

In case the °M Station is not showing a green illuminated LED after it has been plugged into an active AC outlet, the °M Station is defective. If the °M Station is within the warranty period, it can be exchanged at a licensed °MEQU dealer.

### DEFECTIVE °M WARMER UNIT

The °M Warmer device is not working if the green LED does not illuminate within 10 seconds of an AC powered °M Station being connected. Replace the °M Warmer unit with a new °M Warmer unit.

















A flashing or illuminated red LED on the °M Warmer when fluid or blood with an initial temperature below 37°C is passed through the °M Warmer, indicates that the °M Warmer device is defective and must be replaced.















The following table summarises the behaviour of the LEDs and actions to take.

Green LED	Red LED	Status	Cause	Action
off	off	No heating	No power or Warmer is faulty	Check that the °M Station is connected to mains and that the green LED is on. Check the cable connection between the °M Station and Warmer. If there are no issues, replace the Warmer
flashing	off	Warming up	$T < 35.5^{\circ}\text{C}$	Wait for target temperature to be reached (<10 s)
on	off	Temperature good	$36^{\circ}\text{C} < T \leq 43^{\circ}\text{C}$	Monitor infusion and Warmer LEDs
off	flashing	No heating	Warmer has been stored at elevated temperature or Warmer is faulty	If state persists despite cold fluid or blood being passed through the Warmer, replace the Warmer
	on	No heating	Warmer is faulty	Replace the Warmer

## 16 SYMBOLS

The following symbols can be found on products or accessories that constitute the °M Warmer System with °M Station.

SYMBOL	DESCRIPTION	SYMBOL	DESCRIPTION
	Medical Device		The ingress protection level against solid foreign objects and water.
	Refer to Instructions for Use		Manufacturer
	Class II Equipment		Temperature limitation
	Pressure		Do not use if packaging is damaged
	Caution, consult accompanying documents		For single use only. Do not reuse.
	Use by yyyy-mm-dd or yyyy-mm		Serial number
	Catalog number		Dispose product according to WEEE Directive
	Do not resterilize		Keep away from sunlight

SYMBOL	DESCRIPTION	SYMBOL	DESCRIPTION
	Date of manufacturing		GS1 datamatrix
	Keep away from rain		Humidity
	Non-pyrogenic fluid path		Type BF equipment
	Defibrillation proof type BF equipment.		MR Unsafe, items should not enter the MRI scanner room. Patients with MR Unsafe devices should not be scanned
	Batch code		Barcode
	Sterilized fluid path using radiation		The product confirms to European MDD 93/42/EEC or / MDR EU 2017/745. If the mark is accompanied by a number, conformity is verified by the indicated notified body.
	Recycle		Non-ionizing electromagnetic radiation

## 17 TECHNICAL SPECIFICATIONS

DIMENSIONS		
Size		°M Station: 12cm (W); 24cm (H); 5,8cm (D); cable length 275cm °M Warmer: 5cm(W); 10cm(L); 2cm(H)
Weight		°M Station: 1430g, °M Warmer: 110g.
ENVIRONMENTAL		
Continuous Operation	Relative Humidity RH Pressure Temperature	15-95% 60-106kPa 0 – +40°C
Storage and Transportation	Relative Humidity RH Pressure Temperature	15-95% 60-106kPa -20 - +50°C
Transient Operating Conditions	Relative Humidity RH Pressure Temperature	15-95% 60-106kPa -20 – +40°C
Shock and Vibration		EN 1789 + A2 §4.3.2
Electrical Compliance		EN 60601-1
OPERATING PARAMETERS		
Max flow Rate (input temp. of 5°C, output temp. of 36°C)		150 ml/min
Output target Temperature Range		39°C +3°C
Prime Volume		3.5 ml with valves and tubing
Maximum inlet pressure		300mmHg

LED (On Battery Heating Unit)	Green: Solid – °M Warmer is within target temperature Green: Flashing – °M Warmer is below target temperature RED: Flashing – Over Heat Alarm
<b>SAFETY AND MONITORING</b>	
Heater Temperature Monitoring	Heater power shut off before fluid temperature exceeds ASTM F2172 blood warmer standard limits.
Independent Safety Circuit	Shuts off power before fluid temperature exceeds ASTM F2172 blood warmer standard limits.
Alarm Condition	NO HEATING/OVER TEMPERATURE (red flashing diode) NO HEATING/FAULT (red diode illuminated or no LEDs on)
<b>DISPOSABLE HEATER UNIT</b>	
Disposable unit	Sterile fluid path, Non-Pyrogenic Fluid Path, Single Use Only
Sterilization method	E-beam
<b>°M STATION</b>	
Input voltage	100-240VAC
Input current	7,0-4,3A
Input frequency	50-60Hz
Output voltage	20,5VDC
Output current	13,5A
°M Station use life	3 years
Electrical Compliance	EN 60601-1

ME Equipment Type	Transportable
Ambulance types (Road vehicle)	Type A1, A2, B, C (Europe); Type I, II, III, IV (US)
<b>CLASSIFICATION</b>	
Protection against electrical shock	Class 2
Degree of Protection Against Harmful Ingress of solid foreign object and water	<p>°M Station - IP33: IP3X = Protected against solid foreign objects of 2,5 mm Ø and greater. IPX3 = Protected against spraying water (Water sprayed at an angle up to 60° on either side of the vertical shall have no harmful effects)</p> <p>°M Warmer - IP54: IP5X = Dust-protected. IPX4 = Protected against splashing water (Water splashed against the enclosure from any direction shall have no harmful effects)</p>
Mode of Operation	Continuous

## 18 ELECTROMAGNETIC COMPATIBILITY

In Active heating mode, the °M Warmer System with °M Station has been tested for Electromagnetic Compatibility according to EN 60601-1-2 for use in the Professional healthcare facility, in the Home healthcare environments and in ground based medical vehicles.

In the following tables the compliance levels are specified.

### **GUIDANCE AND MANUFACTURER'S DECLARATION - ELECTROMAGNETIC EMISSIONS**

The °M Warmer System with °M Station is intended for use in the electromagnetic environment specified below. The user of the °M Warmer System with °M Station should assure that it is used in such an environment.

EMISSION TEST	COMPLIANCE	ELECTROMAGNETIC ENVIRONMENT - GUIDANCE
RF emissions CISPR 11	Group 1	The °M Warmer System with °M Station uses RF energy only for its internal function. Therefore, its RF emissions are very low and are not likely to cause any interference in nearby electronic equipment.
RF emissions CISPR 11	Class B	The °M Warmer System with °M Station is suitable for use in all establishments including domestic establishments and those directly connected to the public low-voltage power supply network that supplies buildings used for domestic purposes.
Harmonic emissions IEC 61000-3-2	Complies	
Voltage fluctuations / flicker emissions IEC 61000-3-3	Complies	

GUIDANCE AND MANUFACTURER'S DECLARATION - ELECTROMAGNETIC IMMUNITY			
The °M Warmer System with °M Station is intended for use in the electromagnetic environment specified below. The customer or the user of the °M Warmer System should assure that it is used in such an environment.			
IMMUNITY TEST	IEC 60601 TEST LEVEL	COMPLIANCE LEVEL	ELECTROMAGNETIC ENVIRONMENT - GUIDANCE
Electrostatic discharge (ESD) IEC 61000-4-2	±8 kV contact ±2 kV, ±4 kV, ±8 kV, ±15 kV air	±8 kV contact ±2 kV, ±4 kV, ±8 kV, ±15 kV air	The °M Warmer System with °M Station can be used in a dry environment.

Electrical fast transients/bursts IEC 61000-4-4	±2 kV for power supply lines ±2 kV for input/output lines	±2 kV for Charger power supply line Not applicable	Mains power quality should be that of a typical Professional healthcare facility or Home healthcare environment.
Surges IEC 61000-4-5	±0.5 kV, ±1 kV Line-to-line	±0.5 kV, ±1 kV Line-to-line	
Voltage dips IEC 61000-4-11	0 % UT; 0.5 cycle at 0°, 45°, 90°, 135°, 180°, 225°, 215°, 270°, 315° 0 % UT; 1 cycle at 0°  70 % UT; 25/30 cycles at 0°	0 % UT; 0.5 cycle at 0°, 45°, 90°, 135°, 180°, 225°, 215°, 270°, 315° 0 % UT; 1 cycle at 0°  70 % UT; 25/30 cycles at 0°	
Voltage interruptions IEC 61000-4-11	0 % UT; 250/300 cycles	0 % UT; 250/300 cycles	
Power frequency (50/60 Hz) magnetic field IEC 61000-4-8	30 A/m	Not applicable	
			Power frequency magnetic fields should be at levels characteristic of a typical Professional healthcare facility or Home healthcare environment.

NOTE UT is the a.c. mains voltage prior to application of the test level.

#### GUIDANCE AND MANUFACTURER'S DECLARATION – ELECTROMAGNETIC IMMUNITY

The °M Warmer System with °M Station is intended for use in the electromagnetic environment specified below. The customer or the user of the °M Warmer System with °M Station should assure that it is used in such an environment.

IMMUNITY TEST	IEC 60601 TEST LEVEL	COMPLIANCE LEVEL	ELECTROMAGNETIC ENVIRONMENT - GUIDANCE
			Portable and mobile RF communications equipment should be used no closer to any part of the °M Warmer System with °M Station, than the recommended separation distance calculated from the equation applicable to the frequency of the transmitter.

Conducted RF IEC 61000-4-6	3 Vrms 150 kHz - 80 MHz Outside ISM basnds	6 Vrms 150 kHz - 80 MHz
	6 Vrms in ISM and amateur radio bands between 150 kHz and 80 MHz	
Radiated RF IEC 61000-4-3	3 V/m 80 MHz to 2.7 GHz	10 V/m
<b>Test specifications for ENCLOSURE PORT IMMUNITY to RF wireless communications equipment</b>		
<b>TEST FREQUENCY (MHz)</b>	<b>MODULATION</b>	<b>IMMUNITY TEST LEVEL (V/m)</b>
385	Pulse modulation 18Hz	27
450	FM +/- 5kHz deviation 1 kHz sine	28
710	Pulse modulation 217Hz	9
745		
780		
810	Pulse modulation 18Hz	28
870		
930		

Recommended separation distance  
 $d = 0.58 \times \sqrt{P}$ , 150 kHz to 80 MHz

$d = 1.17 \times \sqrt{P}$ , 80 MHz to 800 MHz  
 $d = 2.3 \times \sqrt{P}$ , 800 MHz to 2.5 GHz

Where P is the output power rating of the transmitter in watts (W) according to the transmitter manufacturer and d is the recommended separation distance in meters (m). Field strengths from fixed RF transmitters, as determined by an electromagnetic site survey, <sup>A</sup> should be less than the compliance level in each frequency range. <sup>B</sup>

Interference may occur in the vicinity of equipment marked with the following symbol:

1720	Pulse modulation 217Hz	28
1845		
1970		
2450		
5240	Pulse modulation 217Hz	9
5500		
5785		

NOTE 1: At 80 MHz and 800 MHz, the higher frequency range applies.

NOTE 2: These guidelines may not apply in all situations. Electromagnetic propagation is affected by absorption and reflection from structures, objects and people.

<sup>A</sup> Field strengths from fixed transmitters, such as base stations for radio (cellular/cordless) telephones and land mobile radios, amateur radio, AM and FM radio broadcast and TV broadcast cannot be predicted theoretically with accuracy. To assess the electromagnetic environment due to fixed transmitters, an electromagnetic site survey should be considered. If the measured field strength in the location in which the °M Warmer System with °M Station is used exceeds the applicable RF compliance level above, the °M Warmer System with °M Station should be observed to verify normal operation. If abnormal performance is observed, additional measures may be necessary, such as reorienting or relocating the °M Warmer System with °M Station

<sup>B</sup> Over the frequency range 150 kHz to 80 MHz, field strengths should be less than 6 V/m.

Recommended separation distances between portable and mobile RF communications equipment and the °M Warmer System with °M Station

The °M Warmer System with °M Station is intended for use in the electromagnetic environment in which radiated RF disturbances are controlled. The customer or the user of the °M Warmer System with °M Station can help prevent electromagnetic interference by maintaining a minimum distance between portable and mobile RF communications equipment (transmitters) and the °M Warmer System with °M Station as recommended below, according to the maximum output power of the communications equipment.

Rated maximum output power of transmitter (W)	Separation distance according to frequency of transmitter (m)		
	150 kHz to 80 MHz $d = 0.58 \times$	80 MHz to 800 MHz $d = 1.17 \times$	800 MHz to 2.7 GHz $d = 2.3 \times$
0.01	0.058	0.12	0.23
0.1	0.18	0.37	0.74
1	0.58	1.17	2.3
10	1.84	3.7	7.4
100	5.8	11.7	23

For transmitters rated at maximum output power not listed above, the recommended separation distance  $d$  in meter (m) can be estimated using the equation applicable to the frequency of the transmitter, where  $P$  is the maximum output power rating of the transmitter in watts (W) according to the transmitter manufacturer.

NOTE 1: At 80 MHz and 800 MHz, the separation distance for the higher frequency range applies.

NOTE 2: These guidelines may not apply in all situations. Electromagnetic propagation is affected by absorption and reflection from structures, objects and people.

## 19 ORDERING INFORMATION

Order number    Description

**MWS401**  
°M Station

**MWS421**  
DIN to pole adapter

**MWS422**  
DuoFlex to pole adapter

**MWS441**  
AC Power Cable , EU

**MWS442**  
AC Power Cable, US

**MWS443**  
AC Power Cable, UK

**MWS444**  
AC Power Cable, AUS

**MWS445**  
AC Power Cable, IT

**MWS446**  
AC Power Cable, DK

**MWS201**  
Box of 5 disposable °M warmers





Designed and manufactured in Denmark

°MEQU A/S  
Fruebjergvej 3  
2100 København Ø  
Denmark  
[www.mequ.dk](http://www.mequ.dk)

MQ1-M030-2.0  
2025-04-29